

REVISIONS		
NO.	DESCRIPTION	DATE

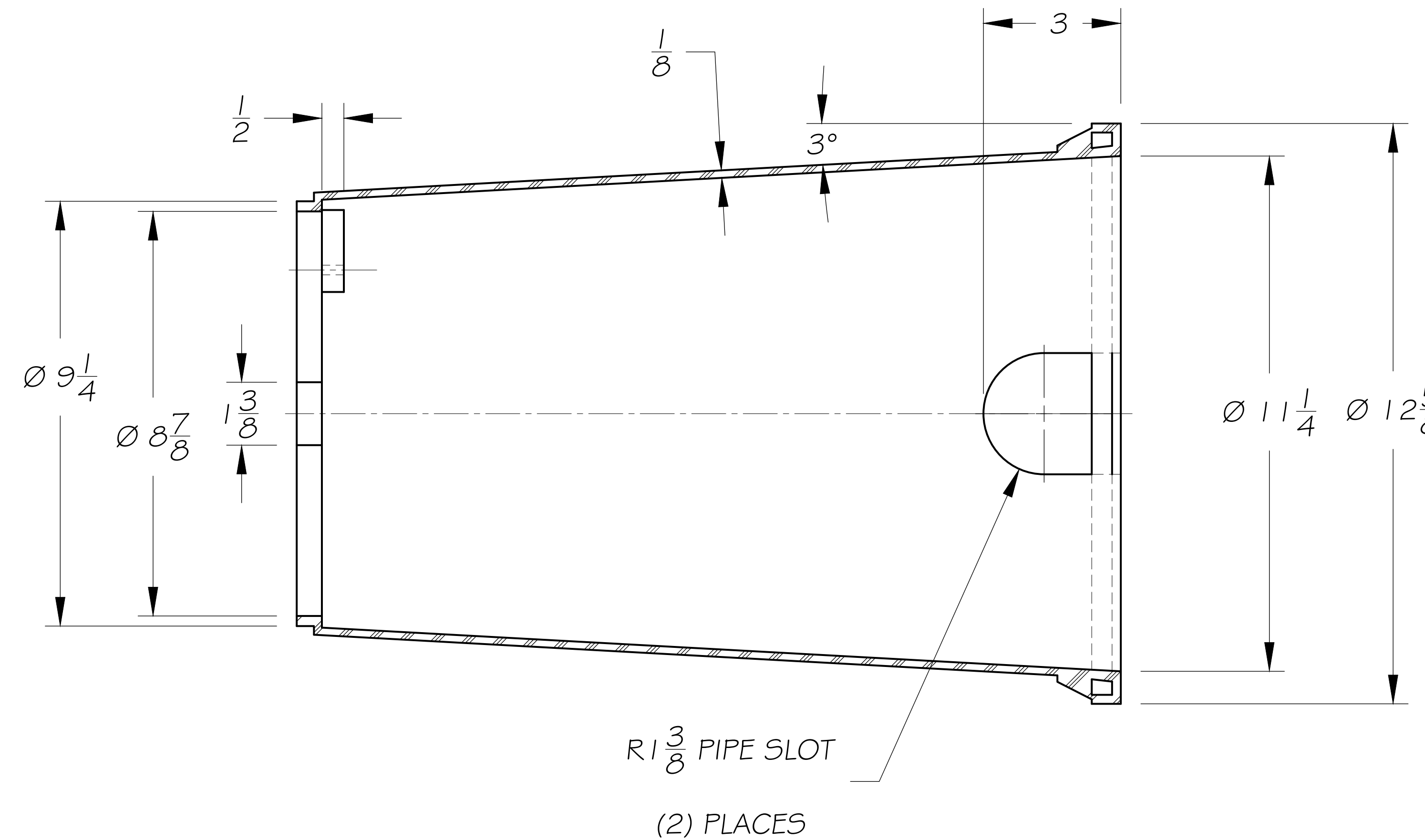

SECTION A-A

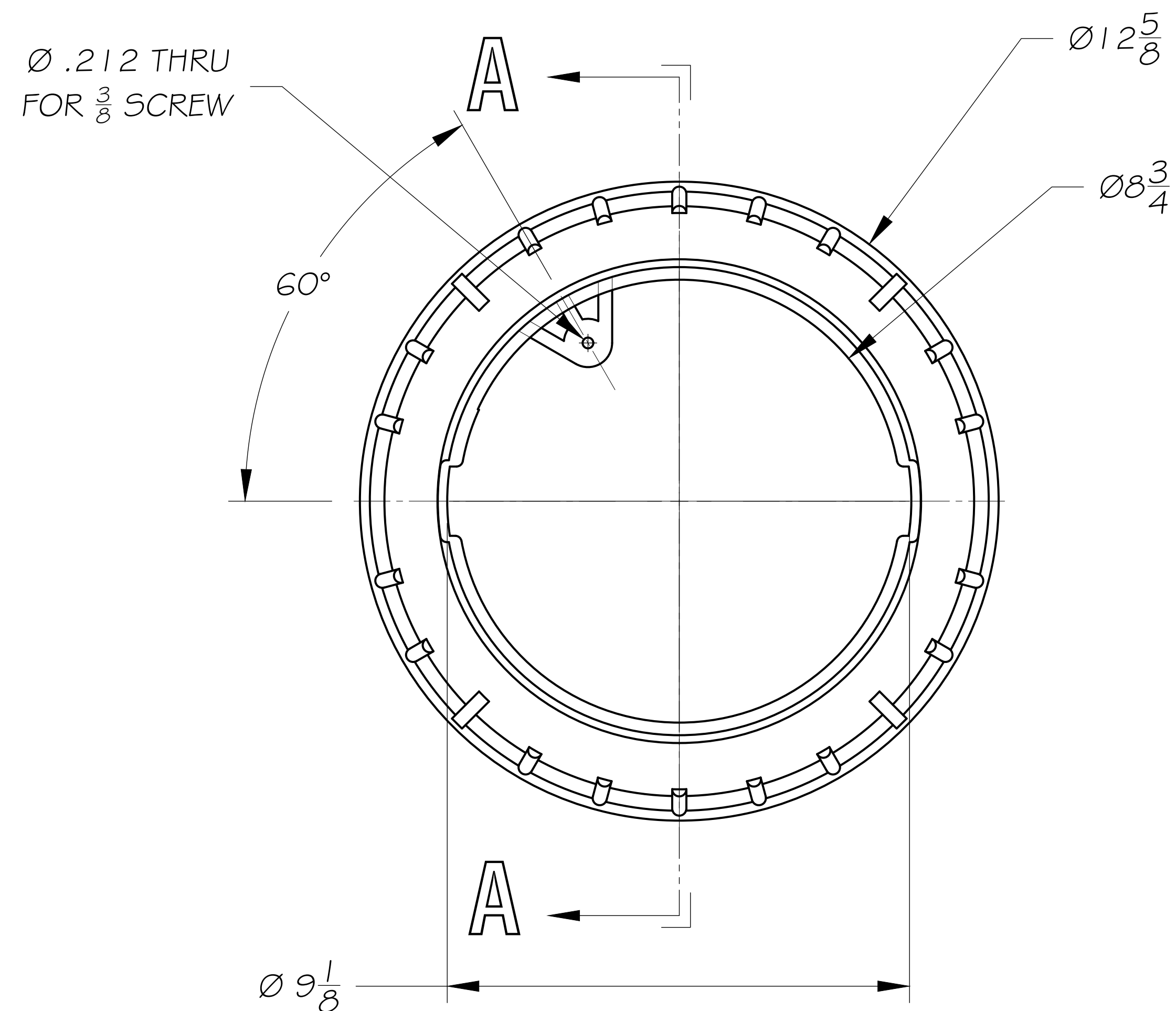
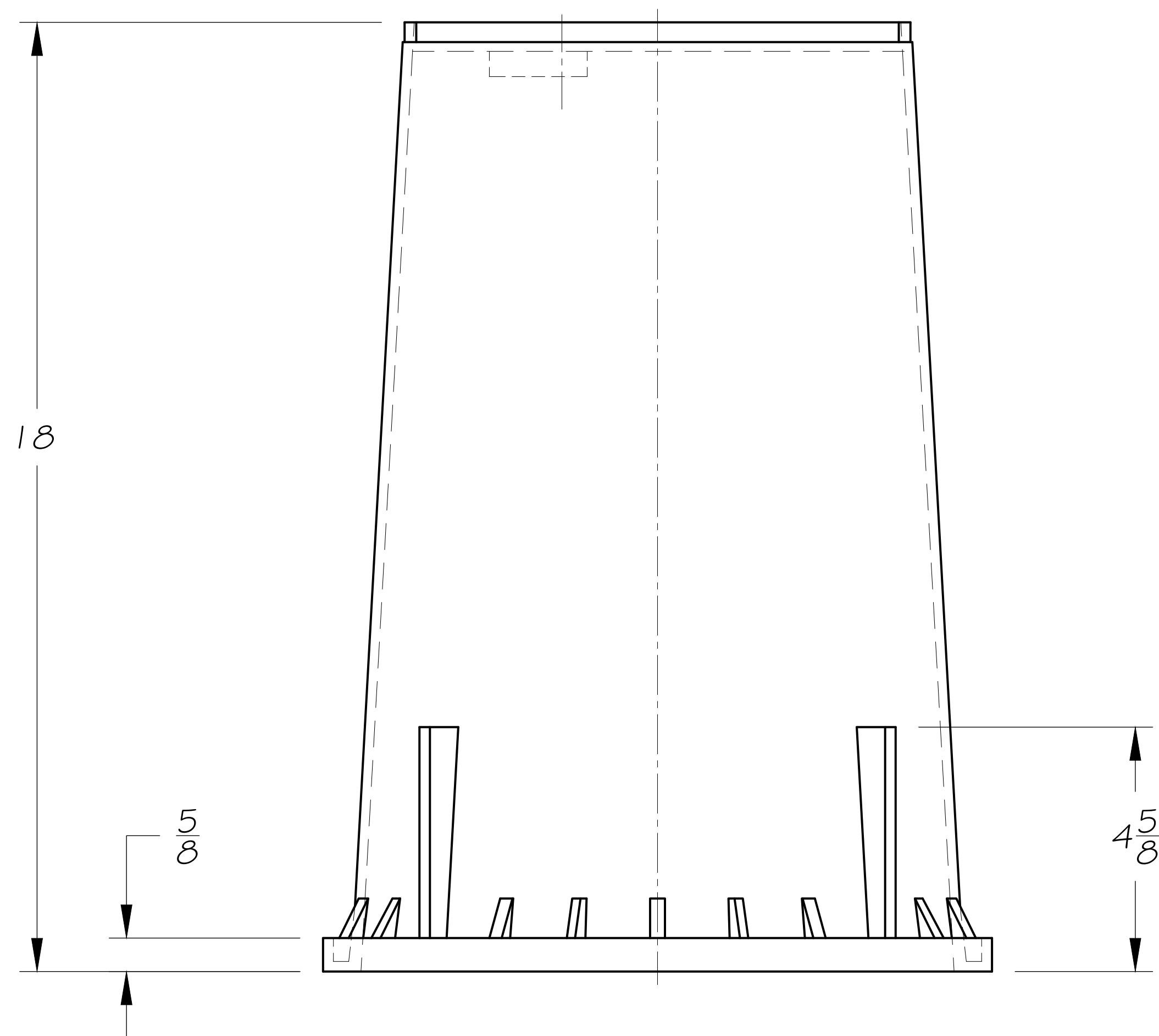

Features and Specifications:

- Material: UV Stabilized Polypropylene
- Estimated Weight: 3 lb 4 oz
- Color: Black
- Reinforced Bottom Edge For Retained Shape
- Twist Lock Lid For Preventing Mower Suction and Blade Damage
- Mouseholes And Knockouts For Pipe Configurations
- Pedestrian, ASTM C857 : Light Duty Non-Vehicular Traffic Situations Only. Actual Load Rating Varies by Box and Lid Combination
- Field Modifications With Any Cutting Tool
- Made in the U.S.A.

JD1001 - 18 ~ 10" ROUND BODY

Drawing is the Property of UTILITY PLASTICS

THIS DRAWING DECLASSIFIED CONFIDENTIAL AND OTHER DATA OF A PROPRIETARY NATURE OWNED BY UTILITY PLASTICS AND MAY NOT BE REPRODUCED OR DISCLOSED TO OTHERS WITHOUT THE PRIOR WRITTEN CONSENT OF UTILITY PLASTICS

UTILITY PLASTICS		DESCRIPTION: JD1001-18 ROUND BODY		
TOLERANCES UNLESS SPECIFIED	MATERIAL	SCALE=1:2	DRAWN	DATE
FRACTIONAL = 1/16"	UV Stabilized Polypropylene	BREAK ALL SHARP EDGES .03 MIN.	S. CORDES	11-23-2021
DECIMALXXX = ±.005				REVISION 00
DECIMALXX = ±.01				SHEET 1 OF 1
ANGULAR = ±1/2°				DRAWING NO: TLD1001-18